

Model Table

No.	Model	Output ●	Output ● ● ●	Recommended controller
1	OPT-RIE50	24V/0.9W	24V/0.9W	OPT-DPA1024E
2	OPT-RIE74	24V/1.8W	24V/3.4W	OPT-DPA1024E
3	OPT-RIE100	24V/3.5W	24V/4.9W	OPT-DPA1024E
4	OPT-RIE150	24V/5W	24V/8.8W	OPT-DPA1024E

Dimensional Drawings [mm]

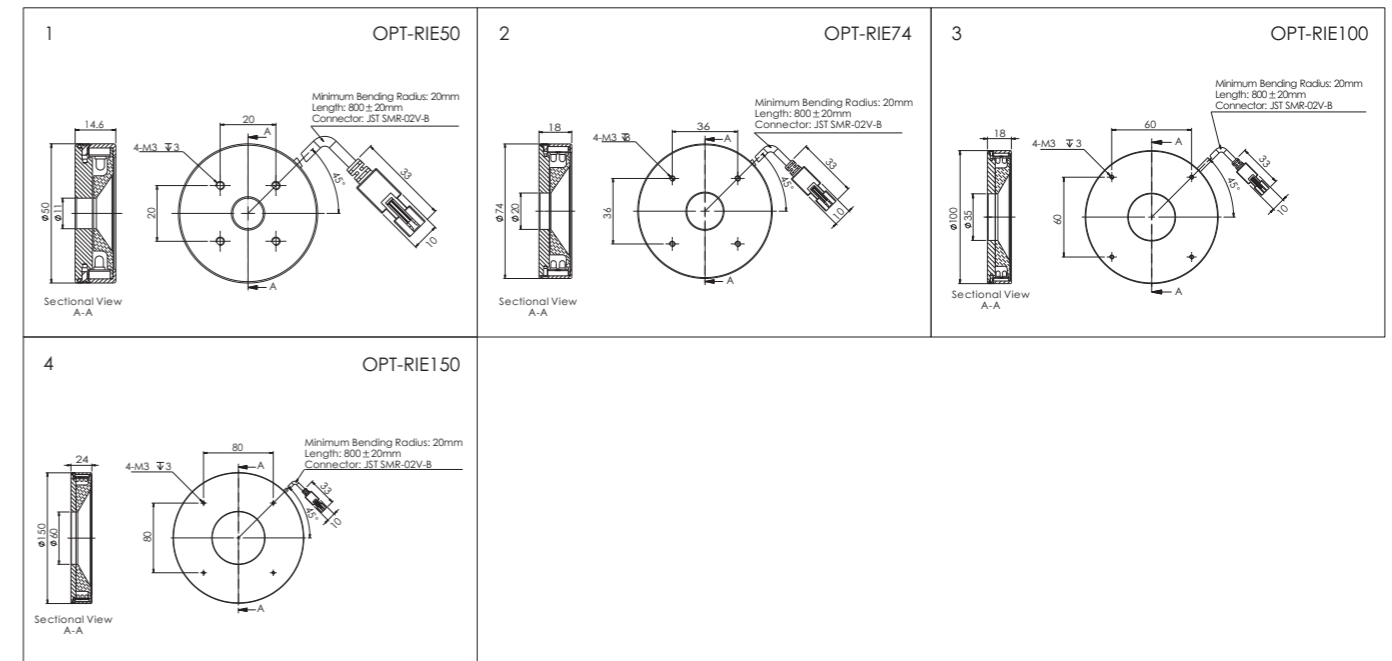

Product Features

- More uniform illumination of large areas compared to standard ring lights
- Provide uniform illumination for rough surface, eliminate flare, and highlight the 3D information
- A special diffuser design reduces reflection and ensures uniform illumination.

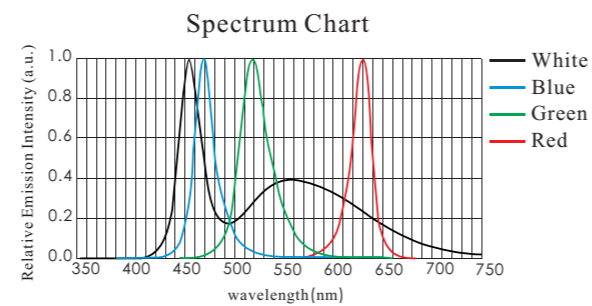
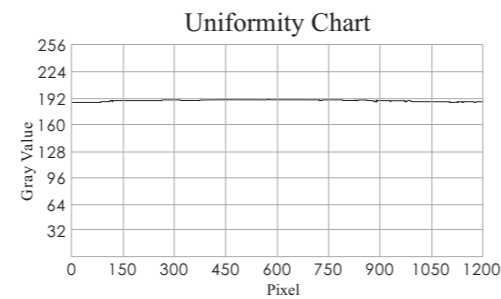

Application Cases

- Localization and measurement of metal objects
- Inspection of surfaces for scratches

Selection Guide

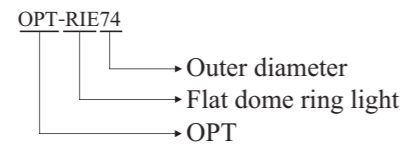

Customization Options

- Color LED
- Mount method
- Heat release method
- Size

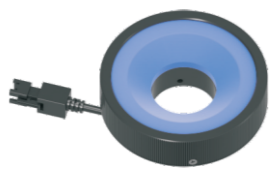

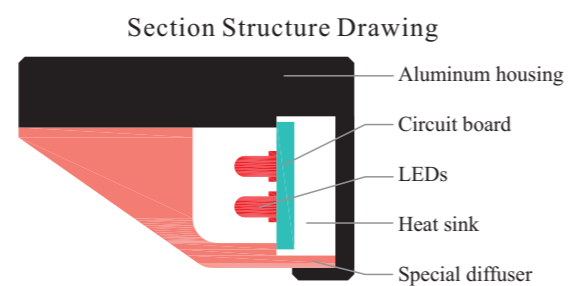

Application Example

Inspected item: Letter recognition on PCBs

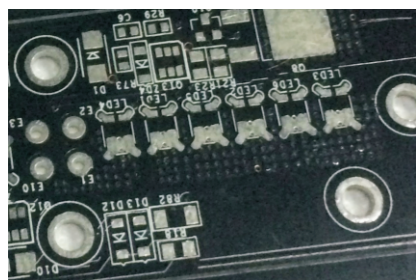

Original Image



Illuminated

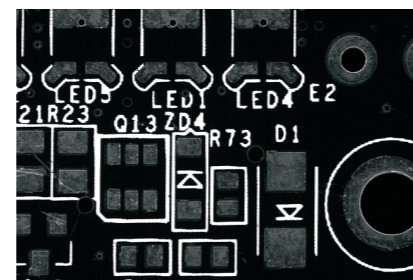

Result Image