

Model Table

No.	Model	Output ●	Output ○ ● ●	Recommended controller
1	OPT-RIW70	24V/0.6W	24V/1.1W	OPT-DPA1024E
2	OPT-RIW90	24V/0.8W	24V/2.4W	OPT-DPA1024E
3	OPT-RIW120	24V/1.3W	24V/2.6W	OPT-DPA1024E

Dimensional Drawings [mm]

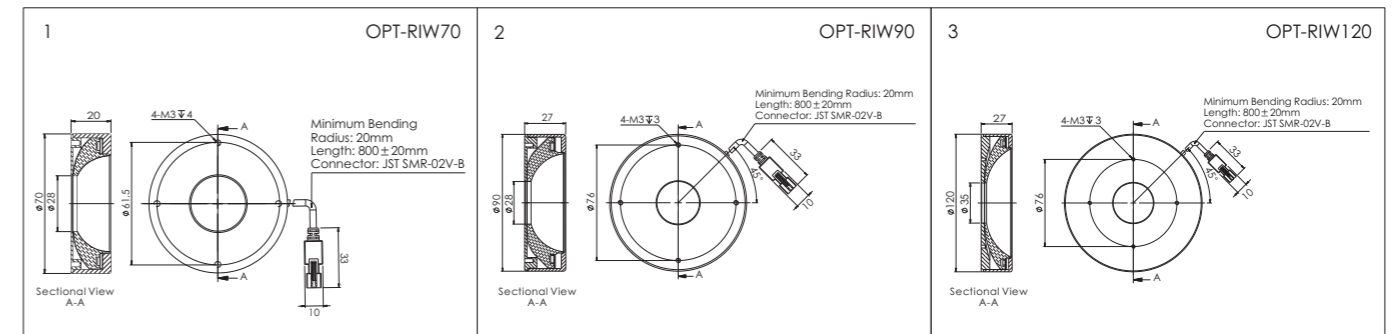

Product Features

- Highly uniform illumination of large area, even illumination on difficult objects without reflections
- Special diffuser design ensures diffuse and uniform illumination

Application Cases

- Inspection of electronic parts
- Localization of electronic parts on PCBs after placement
- Character and image recognition on surfaces
- Geometric measurement

Selection Guide

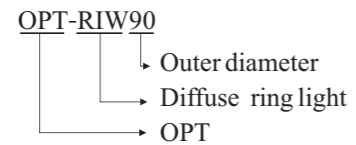

Customization Options

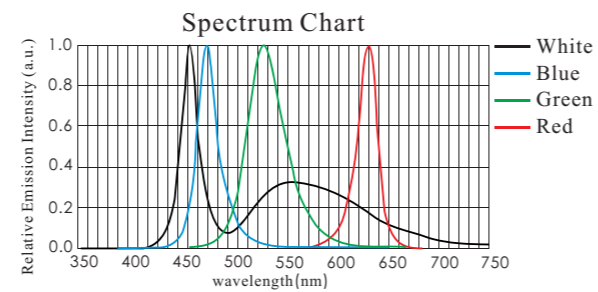
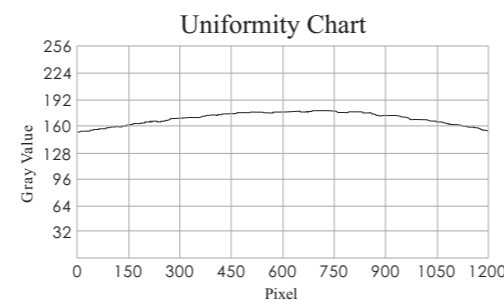

Section structure drawing

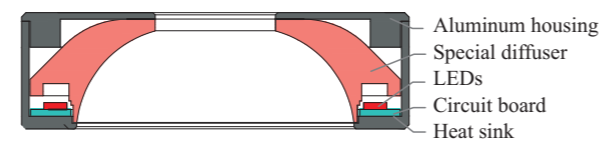

Application Example

Inspected item: Character recognition on remote control

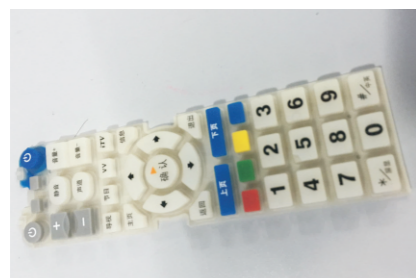

Original Image

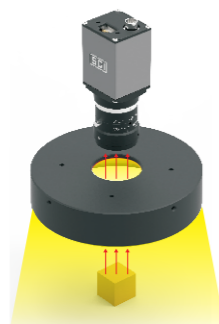

Illuminated



Result Image