

Model Table

No.	Model	Output ●	Output ○●●	Recommended controller
1	OPT-RIF78	24V/1.7W	24V/3.6W	OPT-DPA1024E
2	OPT-RIF88	24V/2.6W	24V/4.1W	OPT-DPA1024E
3	OPT-RIF130	24V/3.3W	24V/6.4W	OPT-DPA1024E
4	OPT-RIF160	24V/5.8W	24V/7.9W	OPT-DPA1024E

Dimensional Drawings [mm]

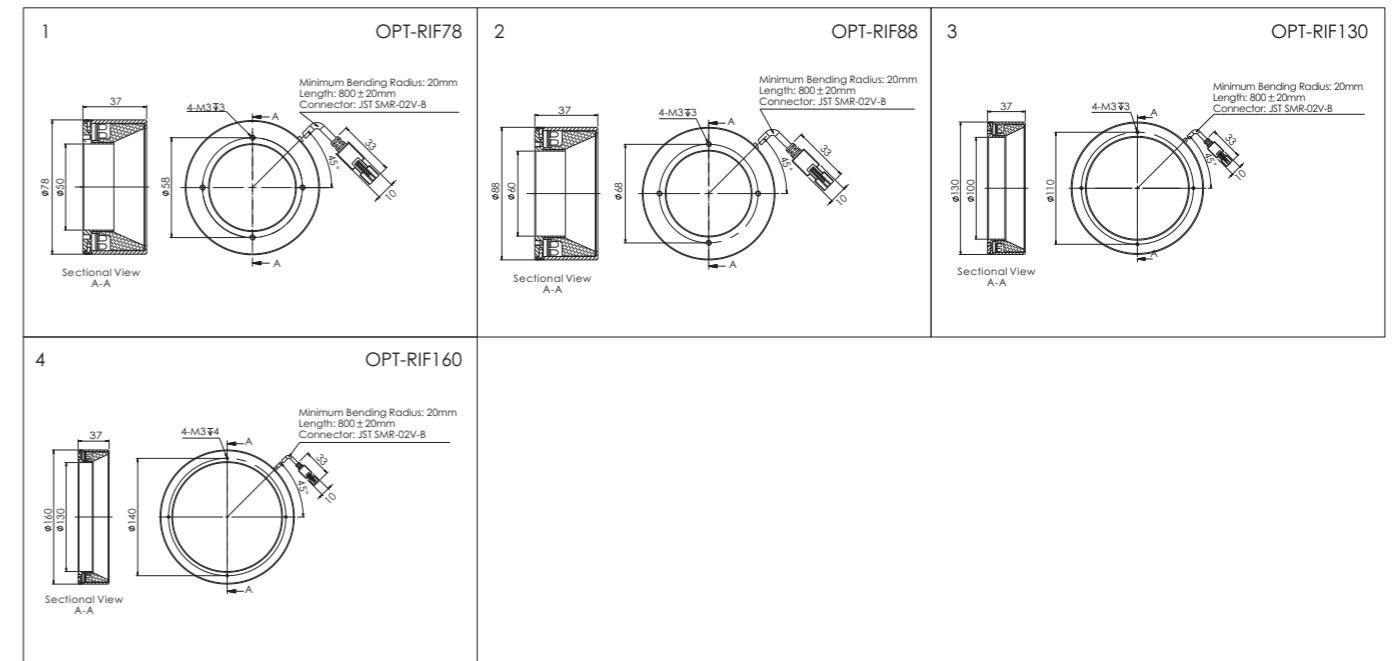

Product Features

- 1 For large round objects or small irregularly shaped objects
- 2 Higher uniformity compared to standard ring lights
- 3 Uniform illumination without shadow
- 4 Different working distances create different results

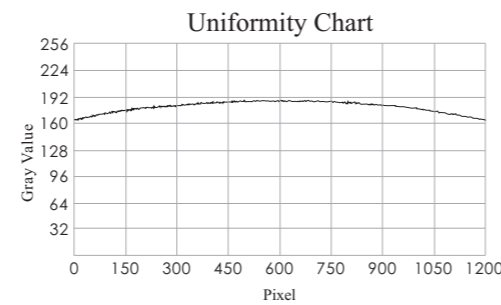

Application Cases

- ◆ Surface inspection
- ◆ Optical Character Recognition
Reading of logos, barcodes, fingerprints

Selection Guide

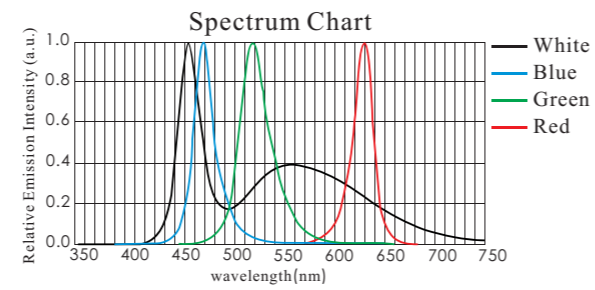
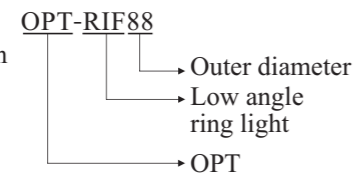

Customization Options

- Color
- Mount method
- Heat release method
- Size



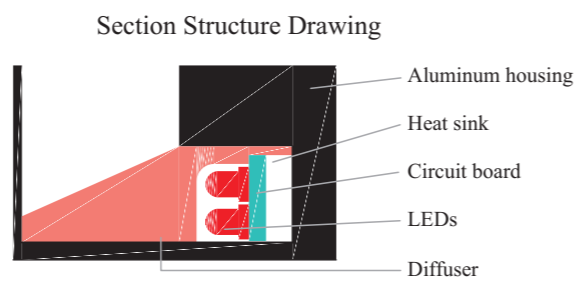

Application Example

Adapter metal plate inspection



Original Image

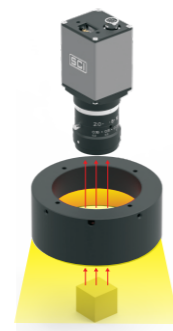

Illuminated

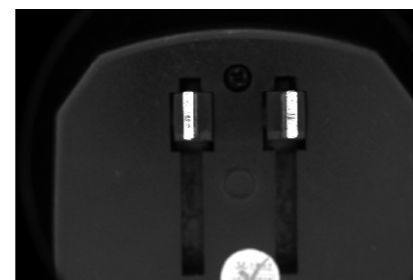

Result Image