

Customized Air Cooled Lights

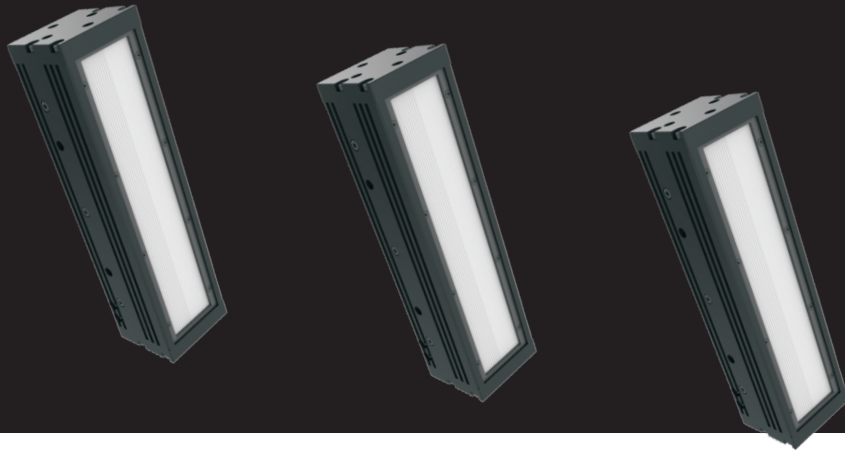

Product Features

- 1 Compact footprint
- 2 Reduced speckles thanks to a special lens design
- 3 Suitable for dust-free environments; requires air compressor

Customization Options

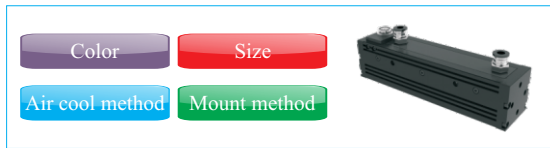

Model Table

Model	Output ●	Output ○ ●	Recommended controller
OPT-LSG197	1.2A/28.8W	3.5A/84W	DPA6024

Dimensional Drawings [mm]

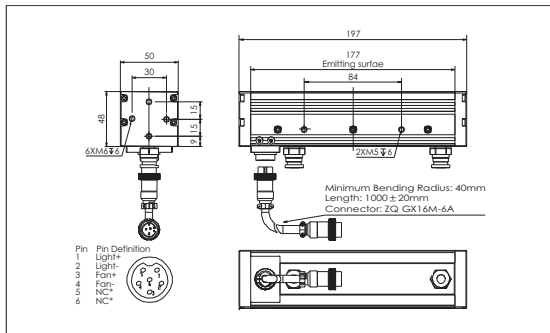

Application Cases

- ◆ Mobile screen surface defects inspection
- ◆ Aluminum surface inspection for scratches
- ◆ Steel surface defects inspection

Selection Guide

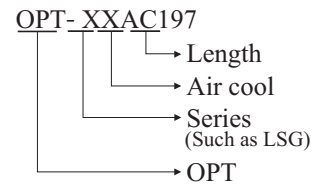

Uniformity Chart

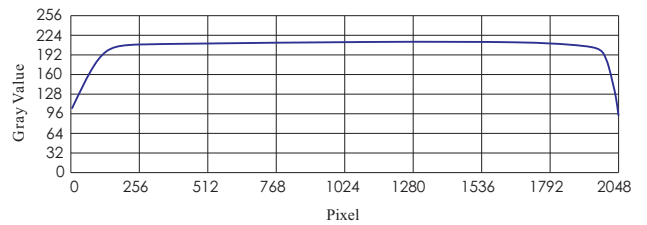

Section Structure Drawing

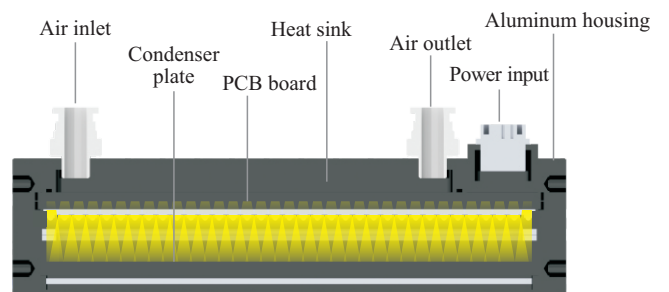

Application Example

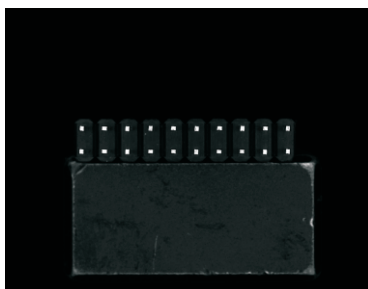

Component pin foot location



Barcode recognition



Aluminum cover surface inspection