

Model Table

No.	Model	Output ●	Output ○ ● ●	Recommended controller
1	OPT-RIP120	0.41A/9.9W	0.37A/8.8W	OPT-DPA1024E
2	OPT-RIP180	1.1A/26.0W	0.78A/18.8W	OPT-DPA1024E
3	OPT-RIP245	--	1.2A/28.8W	OPT-DPA1024E

Product Features

- High-power SMD LEDs and high-uniformity diffuser provide high intensity and shadowless illumination
- Thanks to robust connection makes stability

Application Cases

- Surface inspection of electronic parts on high-speed production line
- Inspection of inner surface of cylinders

Selection Guide

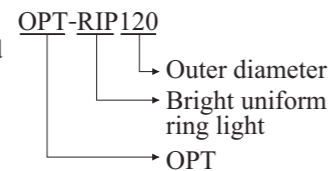

Customization Options

- Color
- Shape and size
- Combination of light sources
- Connector
- Emitting surface
- Mount method



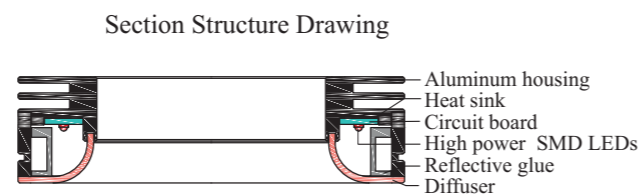
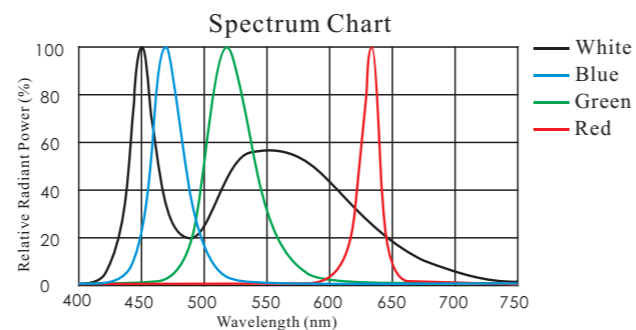
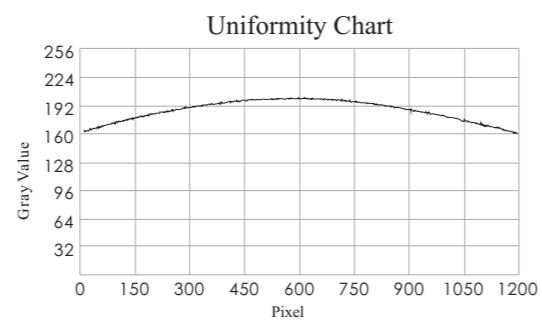

Dimensional Drawings [mm]

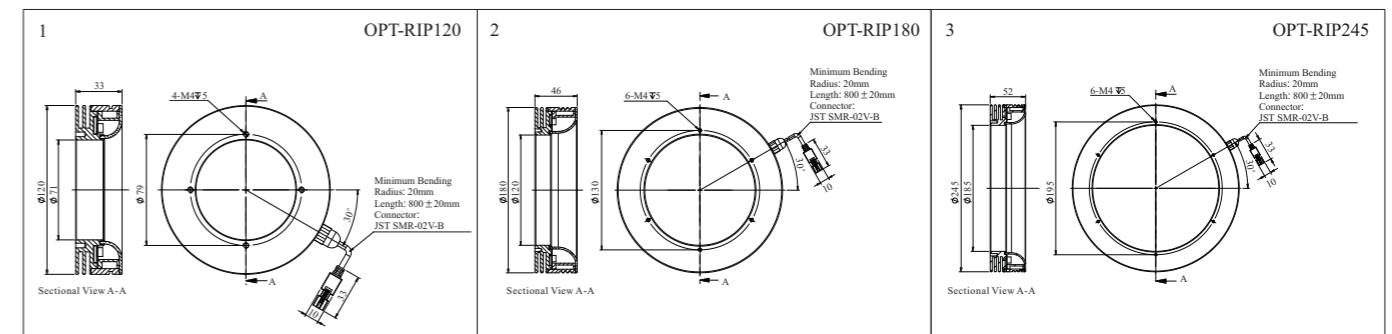

Application Example

Gear surface Inspection



Original Image

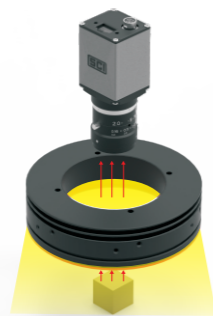

Illuminated

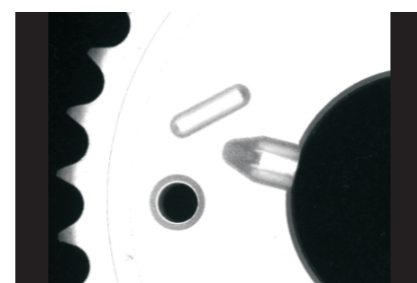

Result Image